

Assembly instruction

Model „Vento short“ with front hinge and lock
For Lambretta Series 2 and 3



Hinge

Position	Part
1	1 x base-plate
2	24 x brass washer for M6
3	2 x lever front
4	8 x self-locking nut M6
5	8 x allen bolt M6x20
6	2 x lever rear
7	1 x seat-plate

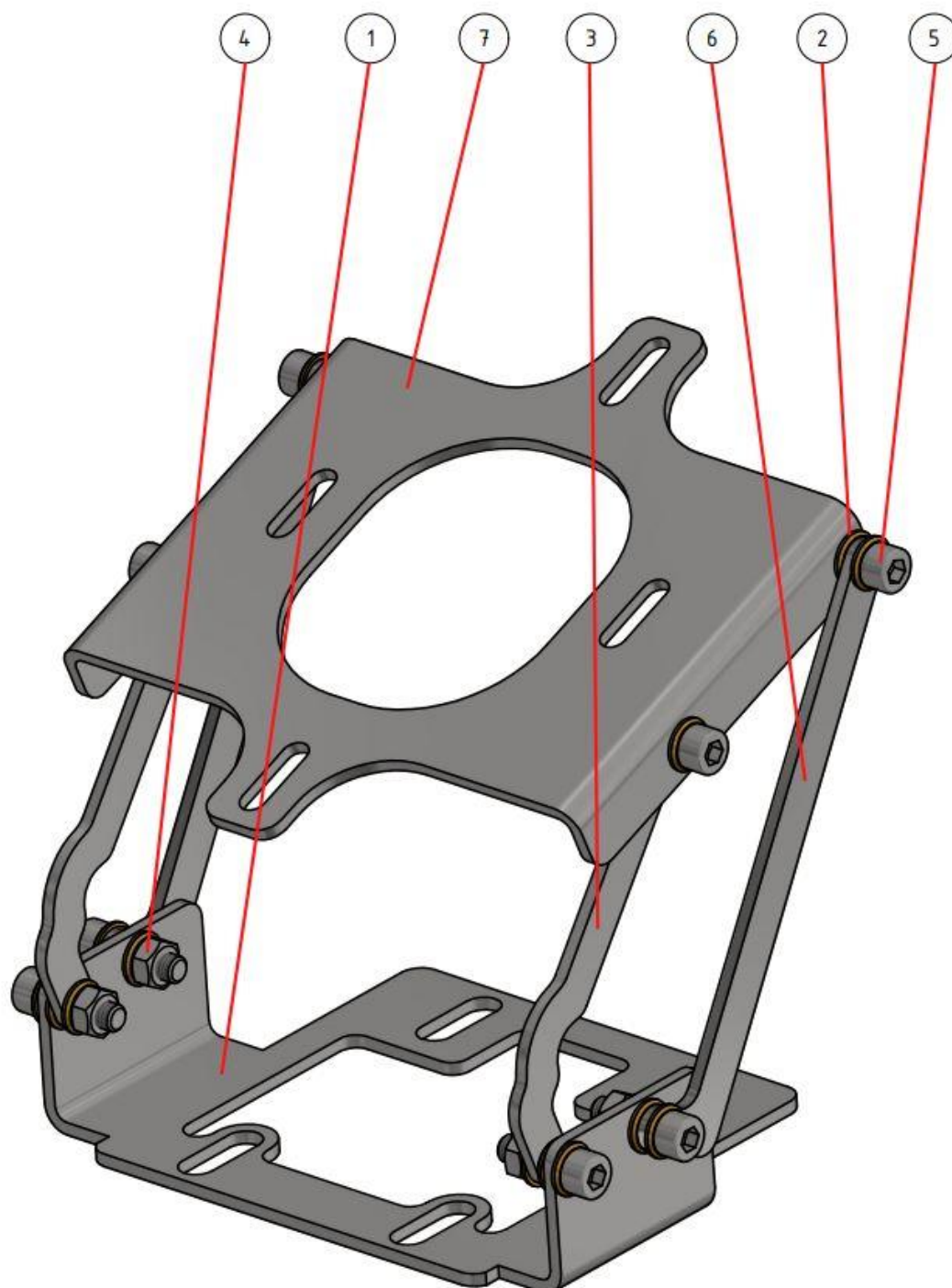

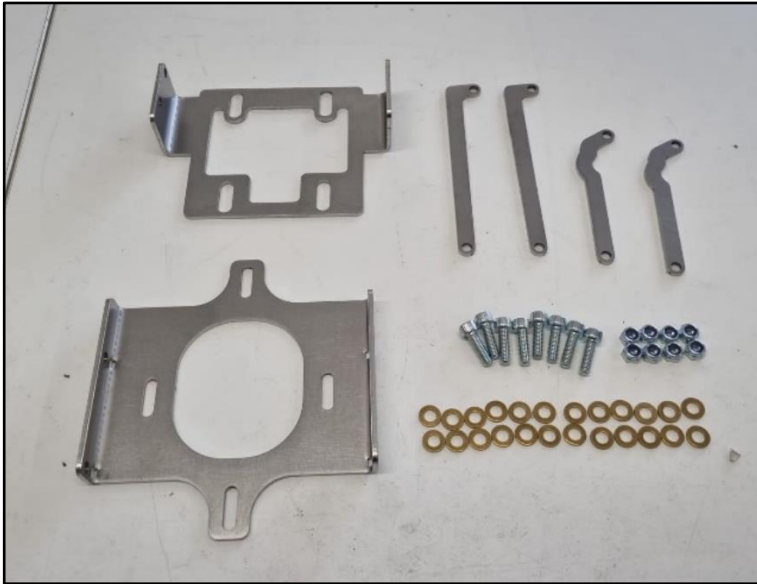

Assembly hinge

- 1 x base-plate
- 1 x seat-plate
- 2 x lever front
- 2 x lever rear
- 8 x allen bolt M6x20
- 8 x self-locking nut M6
- 24 x brass washer for M6



Step 1: Mount the short levers at the front and the long levers at the back with the M6x20 allen bolts, the M6 self-locking nuts and three brass washers. Orientation of the levers: See picture on the left.

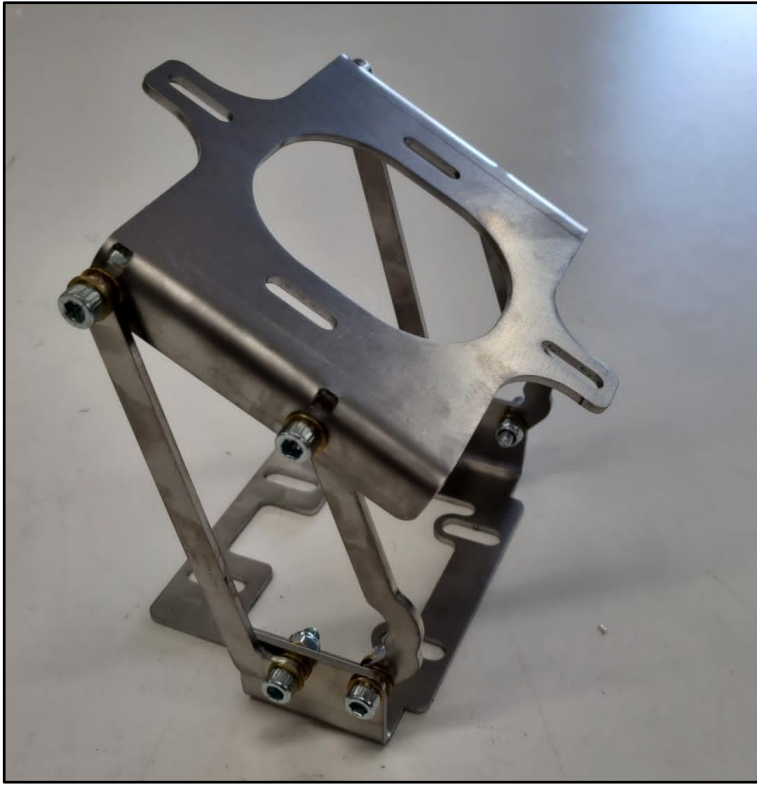

Step 2: Mount all four levers at the upper seat-plate with the M6x20 allen bolts, the M6 self-locking nuts and three brass washers.
Orientation of the base plate: see picture on the left.



Assembly seat

- 1 x upholstered seat with lock
- 1 x stainless steel cover-plate
- 2 x keys
- 4 x allen screw M8x40
- 2 x headless screw M8x55
- 2 x nut M8, standard
- 6 x self-locking nut M8
- 20 x washer M8
- 2 x plastic spacer
- 1 x oval frame bracket
- 1 x locking bracket
- 9 x washer M6
- 6 x spring ring M6
- 7 x spacer nut M6x20
- 3 x self-locking nut M6
- 1 x rubber buffer D=25 / H=25
- 3 x rubber buffer D=25 / H=15
- 3 x lens head bolt M6x10

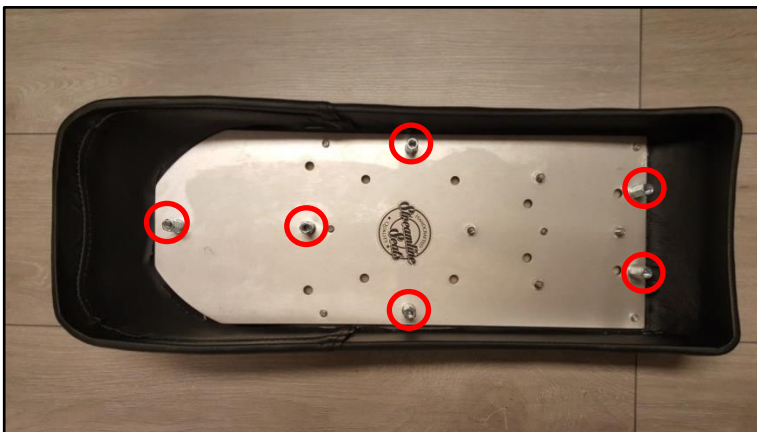

Step 1: Mount the 6 x M6 washers, 6 x M6 spring-rings and 6 x M6x20 spacer nuts according to the picture on the left

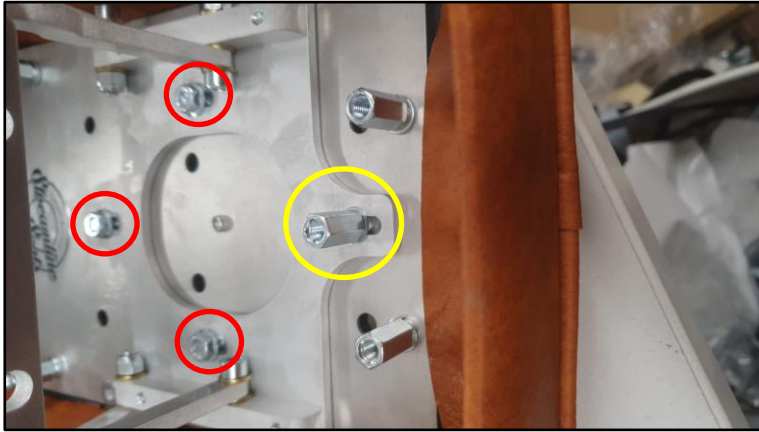

Step 2: Install the hinge at the front of the seat with the help of the three M6 self-locking nuts (red circle). Install one M6x20 spacer nut together with a M6 spring ring at the front (yellow circle). Subsequently test if the hinge opens without any problems.



Step 3: Remove the protective film from the stainless-steel cover-plate.

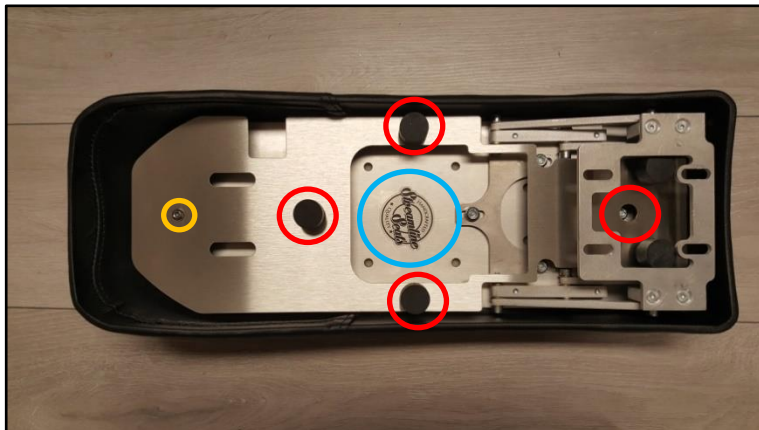

Step 4: Insert the cover-plate into the seat. Screw in the rubber buffers together with one M6er washer (red circle):

Front: 1 x D=25 / H=25
Middle and rear: 3 x D=25 / H=15

Backside: one M6x10 lens head bolt (yellow circle) without M6 washer.

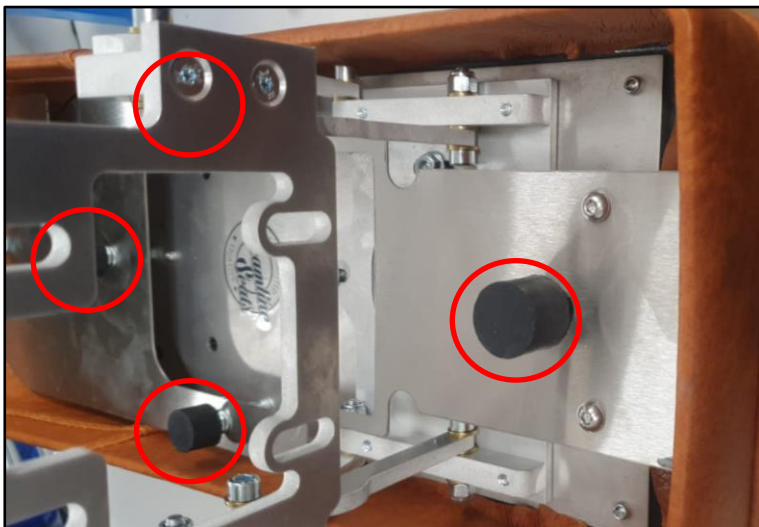

Rubber buffers

Front: 1 x D=25 / H=25
Middle and rear: 3 x D=25 / H=15



Installation seat

Step 1:

Expand the hinge and attach the seat to the front side of the frame by using with the M8x40 allen screws, washers and M8 self-locking nuts (see left picture). Support the hinge on all four holes by placing one or two M8 washers underneath it.

Close the seat and check if the rear side of the seat aligns with the rear side of the frame. If necessary, adjust the horizontal position of the seat accordingly.

Note: the bending of the base plate of the hinge during the fastening is normal.



Step 2:

Rear side frame:

Screw in the two M8 nuts on the M8x55 headless screws. Attach the oval bracket to the frame together with the plastic spacers, the locking bracket and the M8 washers.

Fully assembled fastening-system.: see picture on the left.



Step 3:

Close the seat and use a flashlight to illuminate the inside locking system. Check if the locking bracket that is attached to the lock sits underneath the locking bracket that is attached to the frame after the key was turned. If necessary, adjust the horizontal position of the locking bracket by moving it a back or forward.



Step 4:

Screw out the two rubber buffers on the side of the seat until they make contact with the frame. Adjust the rear buffers so they evenly make contact with the frame. Once the seat is completely adjusted, lock the height of all rubber buffers by tightening the counter nuts underneath the buffers.

Subsequently test if the seat can still be locked after it was closed.



Step 5:

Look through the front gap between the seat and the frame and screw out the front rubber buffer until it evenly makes contact with the frame. Lock the height by tightening the counter nut underneath the buffer.



Step 6:

Opening: Unlock the seat and open it by lifting the front side of the seat until the dead point of the hinge is overcome.

No warranty is given on damages or subsequent damages that were caused by an improper installation.
Due to legal reasons for decoration purposes only.